



Due to the weight of the table, Highly recommended to have suitable lifting equipment such as a forklift with lifting slings & eye bolts or hydraulic engine crane along with the assistance of a second person to assist during the build of the table, being made from steel it is heavy and help should be obtained to avoid any injuries. Always remember to wear the appropriate PPE when working with metal and welding equipment.

Refer to your welder manufacturers

recommendations for the correct settings for your welder to suit the material thickness.

Suggestion of what you will need

Note - this assembly guide is merely a recommendation and should not be followed blindly, if you do not have the equipment or the experience necessary to complete this project you should consider seeking advice from a professional.

- 2pcs x 1000mm of M10 or M12 threaded rod
- 4pcs x 700mm of M10 or M12 threaded rod
- 18pcs x 150mm of M10 or M12 threaded rod
- 48pcs of nuts to match threaded rod
- 96pcs flat washers to prevent damage to the table surface
- 'G' Clamps (or alternative) with an opening of at least 100mm to secure the legs in place during welding.
- Timber planks to assist in raising the table surface off the bench during assembly.
- MIG or TIG welder
- Angle grinder fitted with a fine flap disc
- Soft face hammer to help assemble components
- Engineers file, spanners or shifting spanners

NOTE: You may consider to use other methods and tools to help complete your project, the above list is just a suggestion. For example, a small amount of threaded rod can be welded onto the end of solid steel bar rather than buying full lengths of threaded rod which can save a significant amount of cost. Please ensure you thoroughly read through these instructions carefully before starting the assembly process to ensure you fully understand every aspect of the build to ensure a successful outcome.

Getting Started

Before starting the assembly ensure you have the correct tools & equipment to successfully assemble the table whilst making sure you are wearing the appropriate Safety PPE.



Check for Burrs

It is normal for the components to have small burrs or minor imperfections as part of the laser cutting process. While wearing protective gloves, check the edges of the individual pieces and visually inspect them for any small burrs. If you do happen to find one, use a file to remove any burrs, being careful not to remove too much excess material as it may affect the end result.

Clean Components

The components are supplied with a thin layer rust preventative oil coating to protect it from rust, however, this film can affect the quality of the welds if it isn't removed. Before you start assembling the table, ensure you wipe the individual pieces down with an appropriate oil & grease remover.

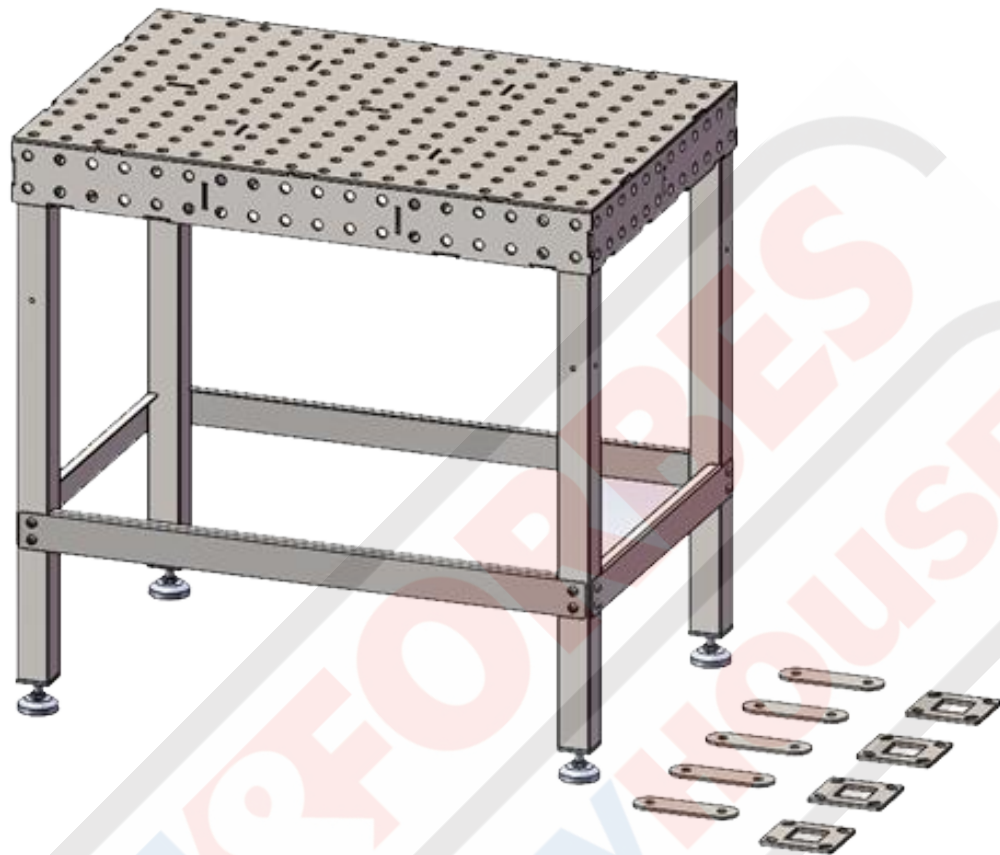

Parts list

Please check that you have all the below parts before you assemble this product

Part	Image	Part	Image
1. Table Top Qty: 1		7. Legs Qty:4	
2. Side Plate- A Qty: 2		8. Leg Brace Qty:4	
3. Side Plate - B Qty: 2		9. Adjustable feet Qty:4	
4. Cross Brackets- A Qty: 1		10. Assembly Straps Qty:5	
5. Cross Brackets - B Qty:2		11. Mounting Screws Qty:16	
6. Base Plate Qty:2		12. Castor Plates Qty:4	

Place the tabletop on top of timber planks or, alternatively, sawhorses. It is best to have the timbers spaced evenly to distribute the weight evenly and reduce distortion during assembly. Ensure the tabletop is level and doesn't rock from side to side, this will help ensure the components fit together correctly.

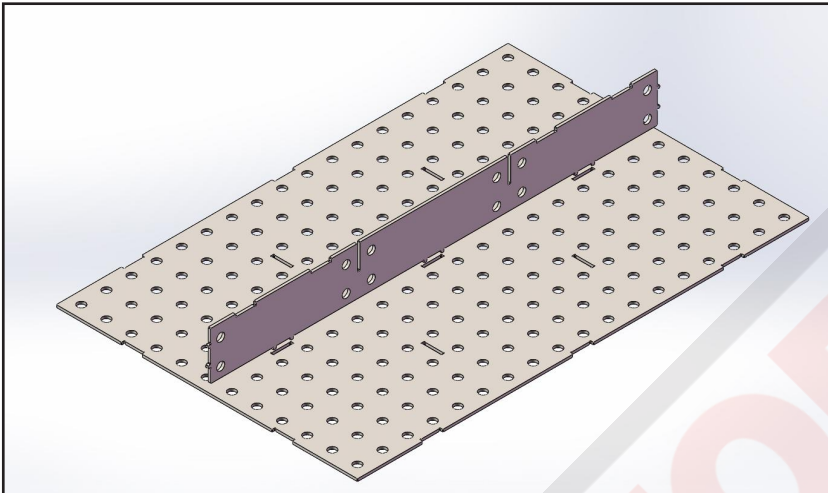
**Step 1**

Insert the ribs into the underside of the tabletop as shown, they should fit together firmly with only a small amount of clearance between the components. Use a soft-face hammer to lightly tap the components into place. If they do not fit correctly the first time, be sure to check for any small burrs and then try again.

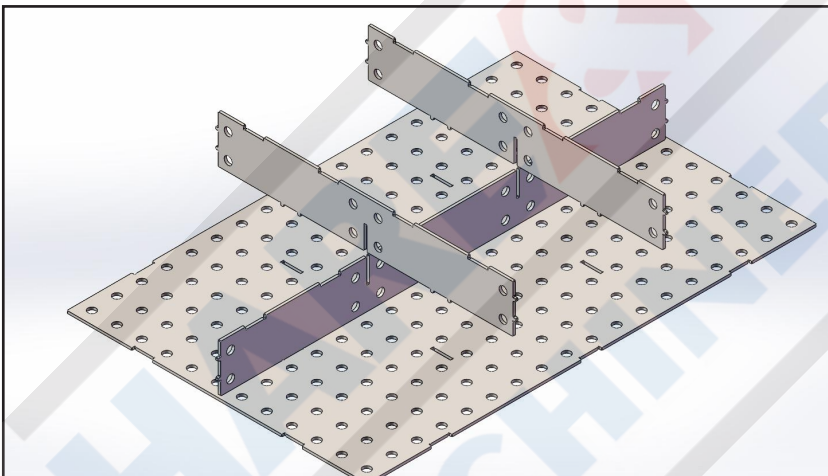
**Step 2**

Add the next 2 ribs, (Part 5)

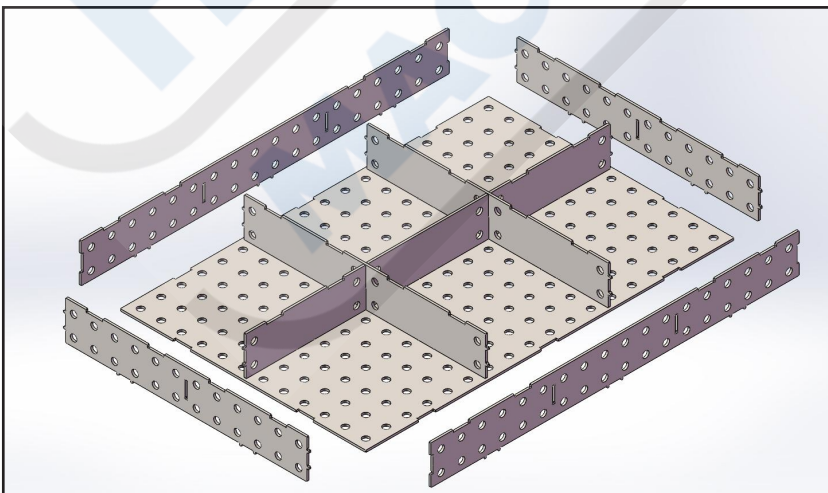
**Step 3**

This step will require some temporary clamps or tie downs to help hold all the pieces in place, This will help to square up the sides of the table and fit each piece into the correct positions.

Add (Parts 2 & 3)

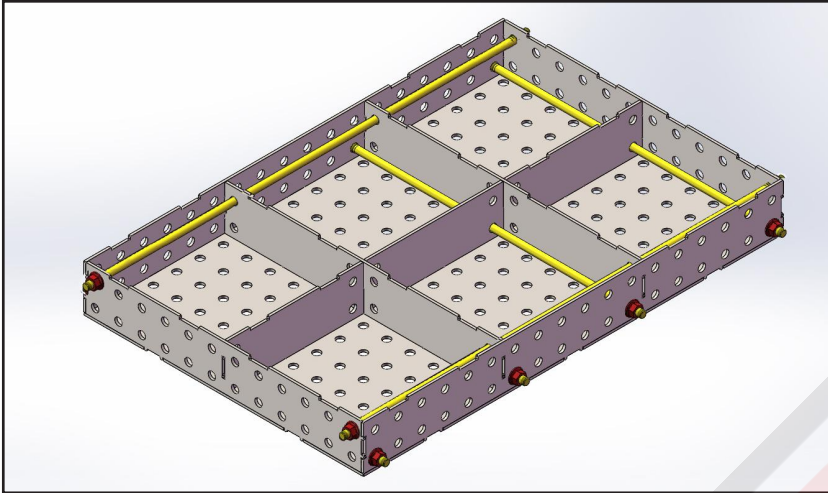
**Step 4**

With the assistance of a second person begin to install 2 opposing table sides, use several pieces of the threaded rod to hold the opposing piece in place during the process. Add the next 2 opposing sides, also using the threaded rod to hold the pieces in place. Ensure the nuts on the threaded rod are only tightened just enough to hold the pieces in place & do not over tighten them.

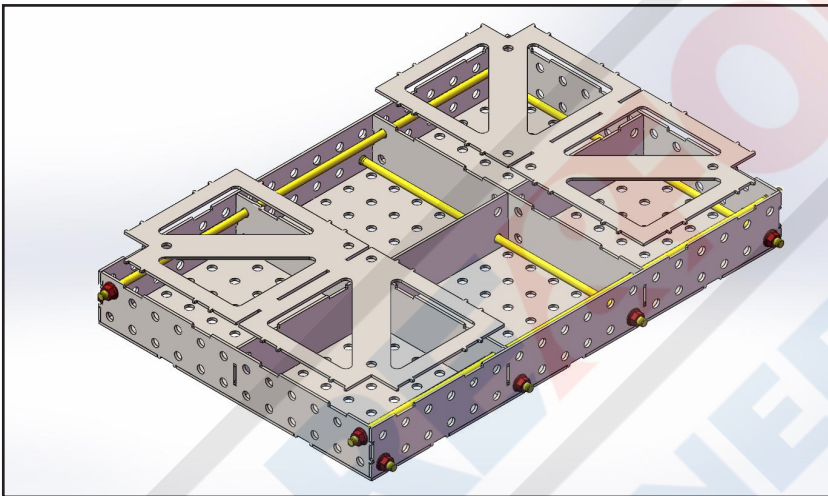
**Step 5**

Install corner plates (Part 6) into each corner, use a soft face hammer to lightly tap components into place to ensure they are correctly seated.

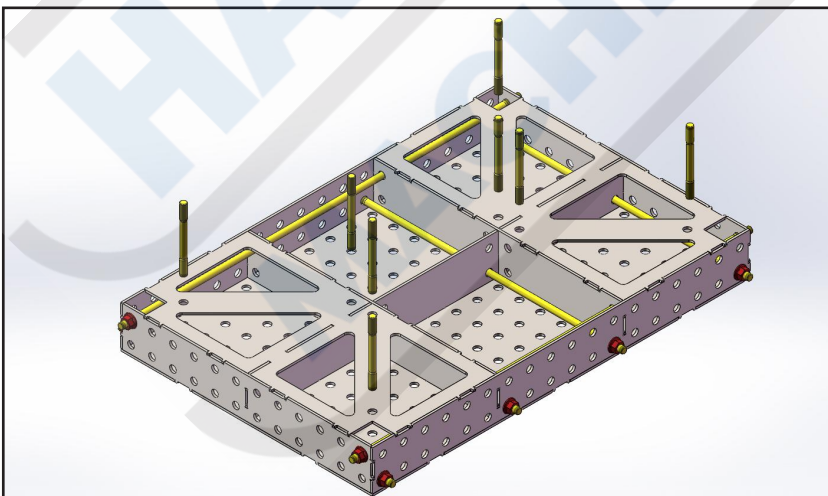
**Step 6**

Insert the threaded rods into the table in both holes of the leg plates and make sure they line up with the corresponding holes on the table top. This is perhaps the most crucial step of the construction, this will make sure the table is perfectly square. (Make sure you place washers in between the nut and the table to protect the metal from scratches)

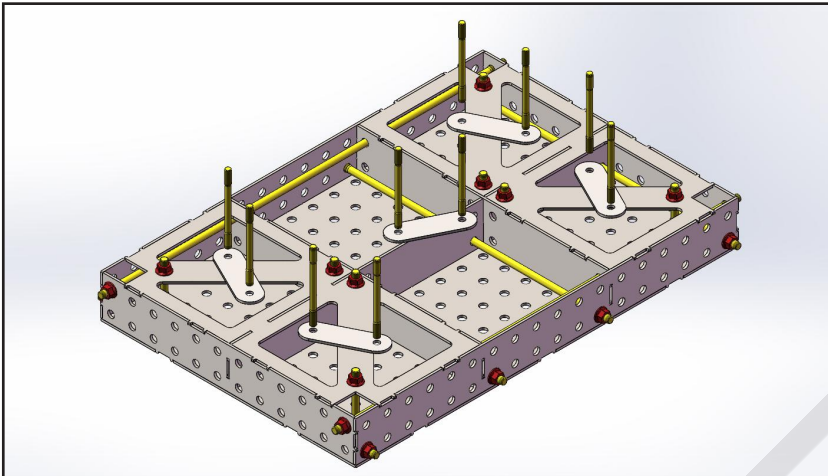
**Step 7**

To aid in assembly, your welding table comes supplied with 5 pieces of pre-drilled flat bar assembly straps to span across the webbing rib joins on the underside of the table. Use the threaded bar or long bolts with the assembly straps to secure the ribs to the tabletop. Ensure you do not overtighten the bolts, otherwise, uneven forces are applied to different parts of the table, which can lead to twisting of the table and a less than desirable final result.

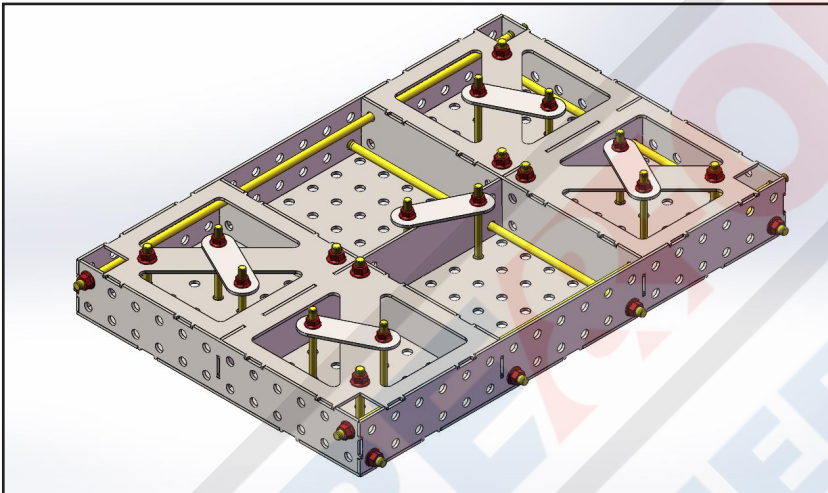
**Step 8**

Tighten the nuts over threaded rod or bolts, the assembly straps should be secure and tight, to check this there should be no gaps between the table and the webbing ribs, With the help of a small flashlight, you can check if there are any gaps between the underside of the table surface and the webbing ribs to ensure they are secured correctly, there should be no gaps between the tabletop and the ribs.

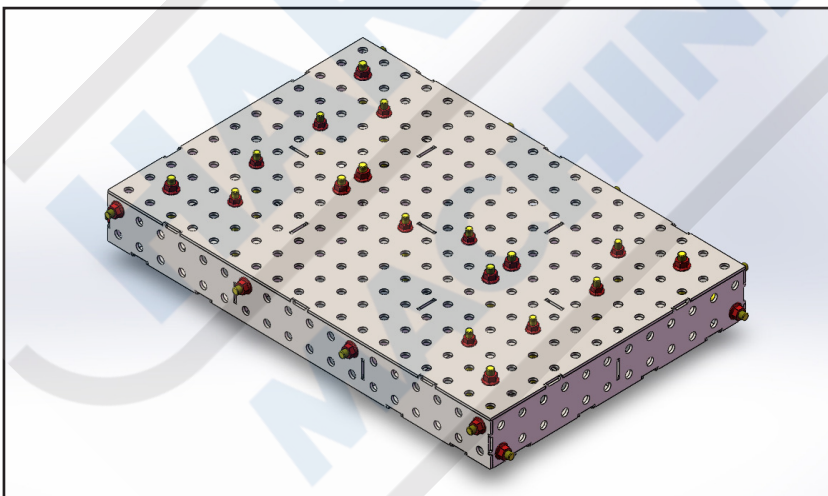
**Step 9**

With the assistance of lifting equipment, carefully turn the table over so that the table surface is upright, and ensure the welding table is placed on a flat, level surface. Before doing any welding, check the flatness with a builders level or straight edge. There should be no gaps between the tabletop and the ribs. If there are any gaps the most likely cause is a small burr, or the bolts have not been tightened correctly. If this is the case, disassemble remove the burr and reassemble. Once again, ensure you do not overtighten the bolts, otherwise uneven forces are applied to different parts of the table, which can lead to a twisting of the table, leading to a less than desirable final result.

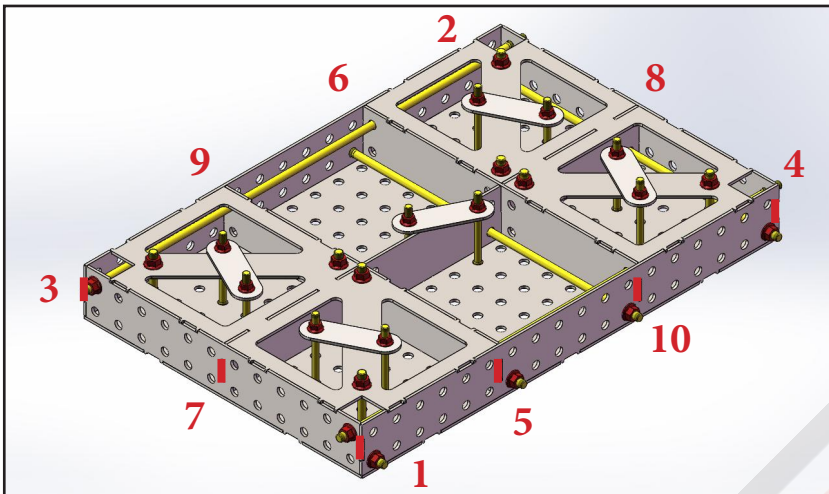

Step 10

Once you are happy with the assembly and flatness, with the assistance of lifting equipment, carefully turn the table over, weld the areas highlighted in red in the sequence as indicated, and weld with a spiral motion so that the two pieces fuse together correctly. Less is more when welding this table together. More welding means more heat and higher chances of warping the table surface.

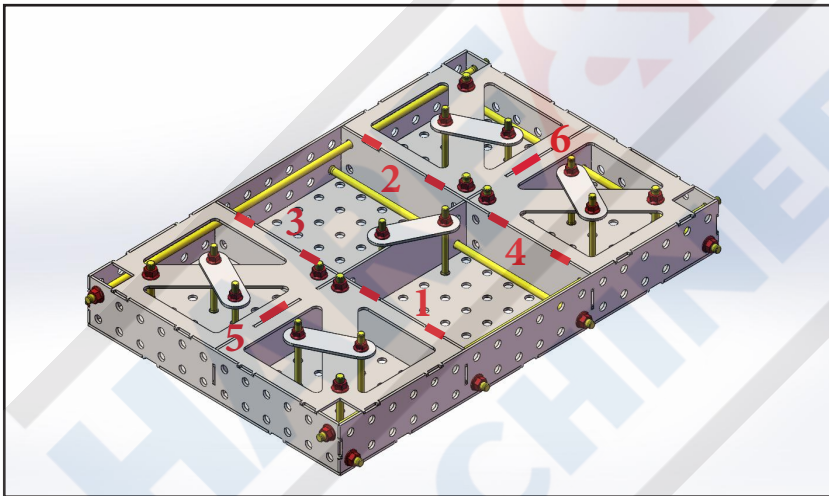

Step 11

Follow this pattern when welding the slots together, Less is more when welding this table together, the more welding means more heat & higher chances of warping the table surface.

Finish by welding 1 to 4 around the edge of the table

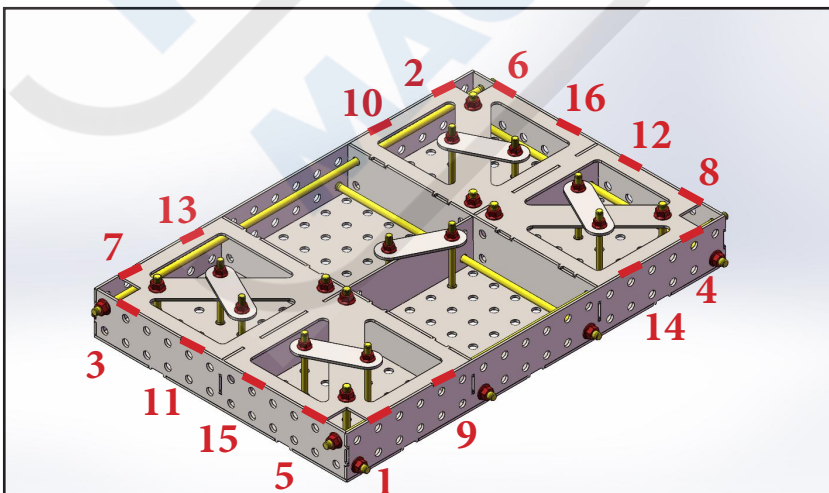

Step 12

Weld the highlighted areas shown in red.

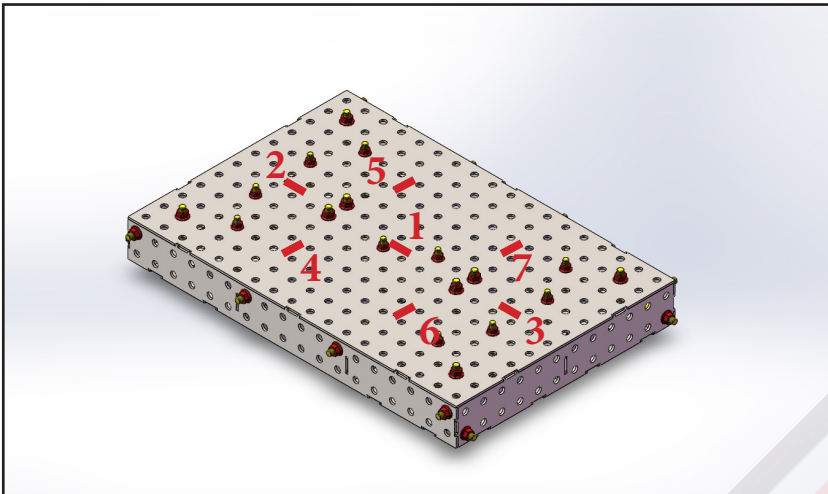
**Step 13**

With the assistance of lifting equipment, carefully turn the table over so that the table surface is upright, and ensure the welding table is placed on a flat, level surface.

Start welding at 1 and work your way towards 7 on the outside of the table.

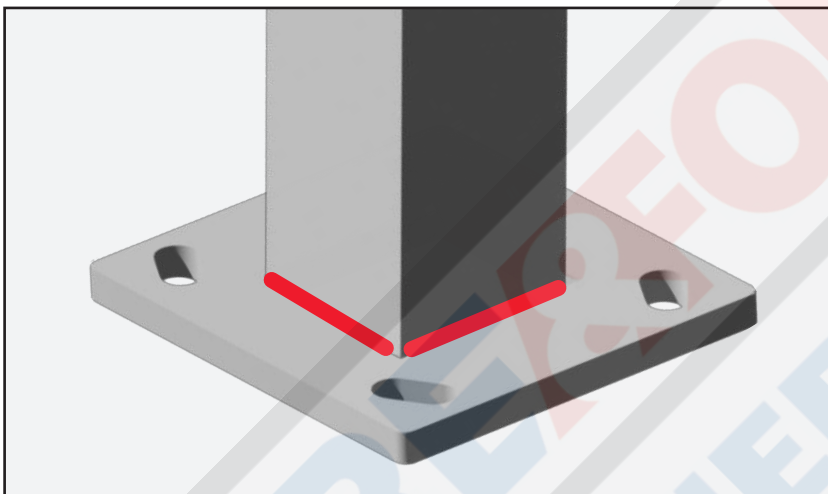
**Step 14**

The 50 x 50mm steel legs come standard with adjustable feet fitted, plus we also supply caster mounting plates. Should you want your welding table to be mobile, simply cut the legs to the desired length to suit the finished table height you require, allowing for the height of the caster wheels. Weld on the caster mounting plates as shown & bolt on your optional caster wheels.

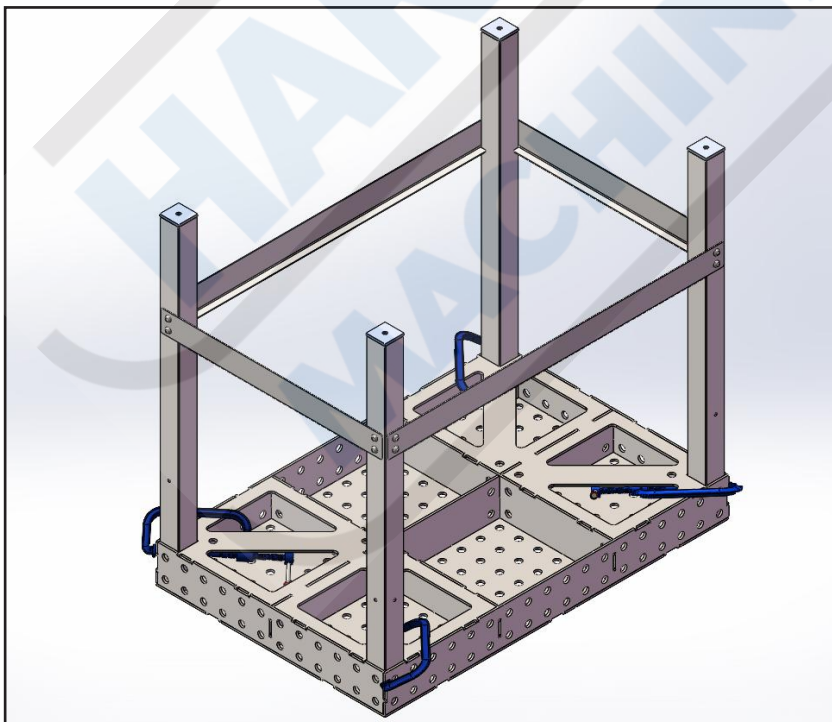
**Step 15**

Once the table has cooled, remove the bolts and assembly straps. Again, with the assistance of lifting equipment, turn the table over with the webbing ribs facing up. Clamp the tube legs into each corner as shown, ensuring the threaded holes are in the correct positions to suit the leg bracing. Lightly clamp the legs into each corner as shown, then bolt the leg bracing into place (do not fully tighten the bolts). Check that the legs are square and level, then proceed to weld as shown. Once finished welding, tighten the leg bracing.

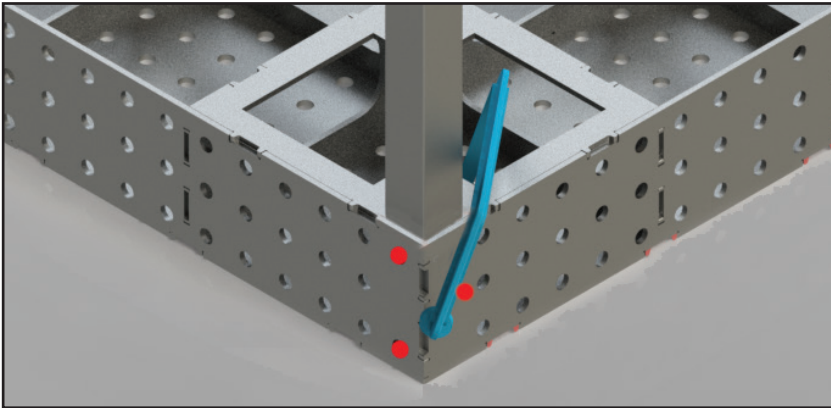
**Step 16**

Make sure when welding the legs that you do not have the welder too hot as this can blow through the legs, doing tack welds and taking short breaks on each hole will help the legs cool down and to allow the heat not to build up. Make sure to weld each leg as shown.



The assembly is now complete. With the assistance of lifting equipment, carefully turn the table over, put it in your desired position, and adjust the leveling feet, check all bolts are tighten and components are secure. Your welding table is now ready for use.